

is shown to hold also for explosive mixtures of oxygen with ethyl alcohol, ether and carbon disulfide. Arguments are advanced to prove that this is a general law of ignition. k is different for each mixture.

Impurities in the explosive mixture are divided into two classes, positive and negative catalysts; the former lower the ignition voltage and the latter raise it. Vapors that burn to form water as one product of combustion will be positive catalysts when present in a small amount and negative catalysts when present in a greater amount. The positive action of a catalyst probably comes from the water formed in its combustion, which precedes the ignition of the main mixture. All impurities that form water seem to act as positive catalysts when present in *any* amount provided there is sufficient extra oxygen to burn the catalyst.

A quantitative relation, also hyperbolic, is worked out for impurities that act as positive catalysts. It is

$$(V - b)(p + a) = c$$

$p + a$ is the pressure of the explosive mixture added as impurity, V the ignition voltage, and b and c are constants for each catalyst.

The two hyperbolic relations explained can be restated thus: (I) *the voltage necessary to ignite a given explosive mixture is inversely proportional to the number of molecules in the path of the spark.* (II) *the ability of a positive catalyst to lower the voltage necessary to ignite a given explosive mixture is, over a wide range, proportional to the number of its molecules in the path of the discharge.*

A study of curves for several catalysts shows that, (III), *the ability of a negative catalyst to raise the ignition voltage is a direct function of the complexity of its molecule.*

WASHINGTON, D. C.

[CONTRIBUTION FROM THE RESEARCH LABORATORY OF INORGANIC CHEMISTRY,
MASSACHUSETTS INSTITUTE OF TECHNOLOGY, No. 5]

THE ANHYDROUS LOWER BROMIDES OF TITANIUM

BY RALPH C. YOUNG WITH WALTER C. SCHUMB

RECEIVED JULY 18, 1930

PUBLISHED NOVEMBER 5, 1930

Considerable work has been done on the anhydrous trichloride and dichloride of titanium, and the di-iodide and trifluoride have been prepared, but we have been unable to find any data concerning the anhydrous lower bromides. The present work had for its purpose the preparation of these latter compounds and a study of some of their properties.

Three methods of preparation were considered and tried: (1) reduction of the tetrabromide by hydrogen; (2) the action of hydrogen bromide on titanium; (3) reduction of the tetrabromide by metals with and without a solvent.

For the preparation of titanium tetrabromide, dry carbon dioxide was allowed to pass through an intimate mixture of pure titanium dioxide (1 mole) and charcoal (2 moles) which was heated in a combustion furnace. After the water vapor was expelled, the carbon dioxide was directed through liquid bromine and the temperature of the furnace was raised until the pyrex tube showed signs of softening. The titanium tetrabromide was collected in a pyrex flask connected to the reaction tube. It was later freed from bromine by being kept in a liquid condition while carbon dioxide was allowed to bubble through it. It was distilled in an atmosphere of carbon dioxide and collected in tubes which were then sealed. The portion distilling at 230° was used. Titanium tetrabromide prepared by the action of hydrogen bromide on titanium was also used in some of the experiments.

In applying method (1) above mentioned, on account of the reversibility of the reaction between titanium tetrabromide and hydrogen, it seemed advisable to employ the hot-cold tube principle which was used in the preparation of the trichloride by Georges and Stähler.¹ Hydrogen, dry and freed from oxygen by passage over hot platinized asbestos, was allowed to bubble through liquid titanium tetrabromide in a 50-cc. flask, (A Fig. 1), sealed directly to a 30-mm. pyrex tube, 66 cm. long, B, through the center of which passed an 8-mm. tube, C. Cold water was conducted to the end of tube C by a 4-mm. tube, D. By this means a temperature gradient in the outer tube of about 750 to 22° was obtained. A hinged type electric furnace was used for heating, the temperature of which was controlled by a rheostat and measured by means of a pyrometer.

Preparation of Anhydrous Titanium Tribromide.—The apparatus was first swept out with hydrogen which entered through a tube sealed to the neck of the flask. After the reaction tube had been heated to redness, the gas was directed through the titanium tetrabromide, which was heated with a burner to such a temperature that about 15 g. per hour was vaporized and passed into the large tube. It was found necessary to employ a rapid stream of hydrogen (about 200 cc. per minute) to insure appreciable yields of product. A dark deposit could be noticed almost immediately at the end of the cold tube. This grew in length and thickness. Some of the reduced product was carried along with the unchanged titanium tetrabromide and hydrogen through tube E into a flask, F, by means of which the unchanged titanium bromide could be recovered.

The deposit on tube C soon assumed a crystalline character. Lustrous blue-black needles extended from the portion adhering to the cold tube to within a few mm. of the walls of the outer tube. Interspersed among the needles were small hexagonal plates. This formation of needles and plates was allowed to continue for about two hours or until it had extended for a distance of about 10 cm. along tube C. The passage of the hydrogen

¹ Georges and Stähler, *Ber.*, **42**, 3200 (1909).

through the titanium tetrabromide was discontinued and the gas allowed to go directly into the reaction tube. The burner and the furnace were shut off and the reaction tube cooled to 250° and then the water flow was discontinued. Any titanium tetrabromide which had condensed on the cooling tube now volatilized. The furnace was next allowed to cool down to room temperature. All the titanium tetrabromide was driven by means of a free flame into the flask, F. Then a current of dry carbon dioxide was substituted for the hydrogen and after the hydrogen was displaced, the tube leading into the flask F was sealed at K. The empty cooling tube was next partly withdrawn through the cork stopper which held it in the large reaction tube. During this process a lively stream of carbon dioxide prevented air from entering through the cork. The black product for the most part fell to the bottom of tube B and by means of tipping and shaking could be brought into tube E without any appreciable hydrolysis taking place. After the flow of carbon dioxide had been stopped, the tube E was sealed at G and the product thus obtained in an atmosphere of carbon dioxide.

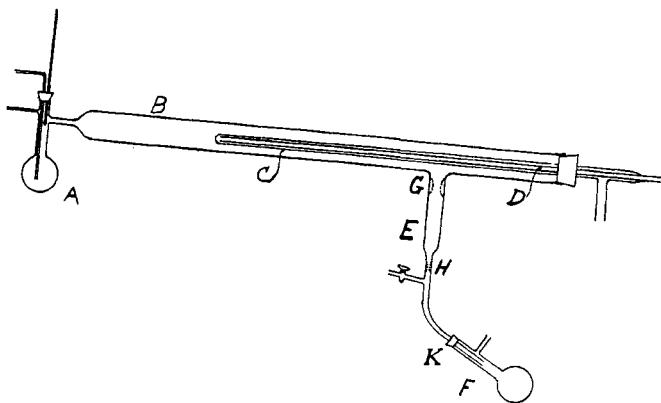

Fig. 1.—Apparatus for the preparation of titanium tribromide.

The tube with contents (carbon dioxide and the bromide of titanium) was weighed, opened and the product immediately dissolved in cold water. The familiar violet solution of trivalent titanium was obtained. There was a slight residue of titanium dioxide which amounted to 0.0035 g. in about 0.50 g. of the product. The titanium was removed from solution by precipitation with ammonium hydroxide as the hydrated oxide, which was afterward ignited and weighed as titanium dioxide. The bromine was determined as silver bromide.

	ANALYSES		
	I	II	Calcd. for $TiBr_3$
Ti, %	16.6	16.6	16.7
Br, %	83.0	82.9	83.3

The solution had the usual reducing properties of trivalent titanium. Ammonia produced a bluish-black precipitate which evolved hydrogen and gradually turned white.

During the course of one hour about one gram of the tribromide was produced and the tetrabromide which passed through the tube unchanged was recovered practically quantitatively.

An examination of the plates and needles was kindly made by Professor M. J. Buerger of the Geology Department of this Institute, who reported as follows. "The plates were hexagonal. The needles were studied with a petrographic microscope, carbon tetrachloride being used as the immersion liquid. The following characteristics were observed. With the light vibrating parallel to the length they were opaque, while they appeared blue with the light vibrating normal to the length. The interference colors can be described as anomalous. The needles possessed parallel extinction which denoted them to be hexagonal, tetragonal or orthorhombic. The formation of two kinds of crystals by a single substance in a reaction where a large temperature gradient is present is described by Tutton² in the case of antimony trioxide." The plates dissolved a little more slowly than the needles but gave the same violet solution. They seemed more compact and denser than the needles. Slight hydrolysis and oxidation brings about a somewhat violet appearance which deepens to red if allowed to continue.

Preparation of Anhydrous Titanium Dibromide.—The sealed tube containing a sample of the tribromide was evacuated with a high vacuum pump and heated in an electric furnace, the small end being immersed in ice water or in a mixture of alcohol and solid carbon dioxide. In decomposing the titanium tribromide, according to the equation $2\text{TiBr}_3 \rightleftharpoons \text{TiBr}_2 + \text{TiBr}_4$, a temperature not greatly exceeding 400° was used in order to prevent as far as possible the decomposition of the dibromide; a 0.5-g. sample required eighteen hours for complete reaction. The proportions of dibromide and tetrabromide obtained from a known weight of the tribromide corresponded fairly closely to the requirements of the above equation. The titanium dibromide proved to be a deep black powder.

The end of the tube containing the volatilized titanium tetrabromide was sealed at H, the tube containing the dibromide was opened in an atmosphere of carbon dioxide and the contents dissolved in cold water saturated with carbon dioxide. A small residue remained undissolved which amounted to 0.0060 g. for 0.2100 g. of the product. Analysis gave the following results.

ANALYSES			
	I	II	Calcd. for TiBr_2
Ti, %	77.5	77.3	76.8
Br, %	22.3	22.8	23.1

² Tutton, "Crystallography and Practical Crystal Structure," p. 1256.

The black powder was very reactive, with strong reducing properties. It caught fire when exposed to moist air and dissolved in water with the evolution of hydrogen. In a mixture of ice and water saturated with carbon dioxide the reaction was much slower but nevertheless noticeable. On heating, titanium dibromide was found to decompose into titanium and titanium tetrabromide. This reaction takes place very slowly at 500°, but at 650° at such a rate that 0.2 g. decomposed in six hours. There was no evidence of hydrogen or hydrogen bromide being formed by the decomposition, which rules out the possibility of hydrogen being a part of the compound; nor was there any appearance of free bromine.

The following equations indicate two possible ways in which titanium tribromide could be formed from the tetrabromide:

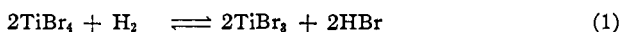

The surface of the reaction tube in the hot zone is considerably attacked and black metallic titanium is first formed thereon. This then appears to react with the glass. It is reasonable to suppose that titanium dibromide is formed by reduction in a somewhat cooler zone and it was proved by a separate test that titanium tribromide can be formed with the furnace at 400°. In other experiments, a thermocouple enclosed in a pyrex tube in the reaction zone midway between the cooling tube and the inner surface of the large tube, which was heated to 750°, registered 400°. No reduction product was obtained on the side toward the hot surface of the large tube, while the product did form between the tube containing the thermocouple and the inner cold tube. The formation therefore took place below 400°.

A study was made of Reaction 2. In the same apparatus used for the preparation of titanium tribromide, titanium dibromide was formed in an atmosphere of hydrogen according to the equation $2\text{TiBr}_3 \rightleftharpoons \text{TiBr}_4 + \text{TiBr}_2$, at 450°, no water having been allowed to circulate in the cooling tube. The needles and plates (TiBr_3) changed to a very black powder. Titanium tetrabromide was then passed with hydrogen through the furnace and the temperature gradually raised from room temperature. At 280° there developed the distinctive bluish-black appearance of the tribromide and at 380° all appeared to be changed over. The product dissolved in water to form a solution which possessed the properties of trivalent titanium.

Action of Hydrogen Bromide on the Lower Bromides of Titanium and Titanium Metal.—Titanium tribromide was made as described previously and hydrogen bromide, prepared as usual from hydrogen and bromine with the aid of a platinized asbestos catalyst, and carefully freed from bromine by ferrous bromide and from water by calcium bromide, was passed through the reaction tube containing the solid. The furnace

temperature was gradually raised; at 250° reaction took place slowly with the formation of titanium tetrabromide and hydrogen and above 350° became very rapid.

Likewise, titanium dibromide was produced in the large pyrex reaction tube in the manner described above, hydrogen bromide was passed over it, and the temperature of the furnace gradually raised. The black titanium dibromide began to assume the brilliant blue-black color of the titanium tribromide at 160° and some titanium tetrabromide was also produced. The non-volatile product was dissolved in water and proved to be titanium tribromide.

Titanium metal was found to react with hydrogen bromide at 300° and very slowly slightly below this temperature. Experiments were conducted at 450° and at 300° to see in which case more of the non-volatile bromides were produced. At 450° the proportion of non-volatile product to volatile titanium tetrabromide, calculated in moles, was 1 to 20, while at 300° the proportion was 1 to 2 and only in the latter case was there evidence of the presence of the dibromide. Consequently the formation of incompletely halogenated products is favored by low temperature, a result which is similar to that noted in the action of hydrogen bromide on silicon.³

Finally, the reduction of titanium tetrabromide by means of metals, namely, titanium, mercury and silver, was studied. Titanium tetrabromide was heated with titanium in a sealed tube at 300° for four hours. Black needles of titanium tribromide, of the same general appearance as already described, were formed. Mercury was also found to reduce titanium tetrabromide when the two substances were heated in a sealed tube at 300°. If a sealed tube containing a benzene solution of titanium tetrabromide and mercury is rotated, the reduction to titanium tribromide and mercurous bromide is practically quantitative,⁴ both products being insoluble in benzene. Attempts to separate the two by sublimation were not successful. Water dissolved the titanium compound and the solution gave the usual tests for trivalent titanium. Silver was found to react in a manner similar to mercury.

Summary

Anhydrous titanium tribromide was prepared in a mixture of two crystalline forms by reduction of the tetrabromide with hydrogen by the use of the hot-cold tube principle. In the study of its properties, it was found to decompose at 400° into titanium tetrabromide and titanium dibromide. The reverse reaction was also carried out by the passage of vapors of the tetrabromide over heated titanium dibromide. Titanium dibromide de-

³ Schumb and Young, *THIS JOURNAL*, 52, 1464 (1930).

⁴ The titanium tribromide formed from 4 g. of titanium tetrabromide by reduction with 10 g. of mercury in 20 cc. of benzene reduced 26.5 cc. of 0.4 *N* ferric alum solution. This is equivalent to a yield of tribromide of about 97%.

composes into titanium metal and titanium tetrabromide, very slowly at 500° but rapidly at 650°.

Both the di- and tribromide react with hydrogen bromide to produce the tetrabromide. Titanium metal reacts with hydrogen bromide to produce a greater proportion of non-volatile bromides (TiBr_2 and TiBr_3) to the tetrabromide at 300° than at 450°.

At 300° titanium metal suspended in titanium tetrabromide brings about partial reduction to the tribromide. Silver and mercury reduce titanium tetrabromide, dissolved in benzene, to titanium tribromide; in the case of the latter metal the reduction is practically quantitative.

CAMBRIDGE, MASSACHUSETTS

[CONTRIBUTION FROM THE RESEARCH LABORATORY OF PHYSICAL CHEMISTRY,
MASSACHUSETTS INSTITUTE OF TECHNOLOGY, No. 247]

THE THERMODYNAMIC TREATMENT OF CHEMICAL EQUILIBRIA IN SYSTEMS COMPOSED OF REAL GASES. III. MASS ACTION EFFECTS. THE OPTIMUM HYDROGEN: NITROGEN RATIO FOR AMMONIA FORMATION IN THE HABER EQUILIBRIUM

BY LOUIS J. GILLESPIE AND JAMES A. BEATTIE

RECEIVED JULY 24, 1930

PUBLISHED NOVEMBER 5, 1930

Although the mass action law has often been applied to experimental studies of gaseous equilibrium, there is little or no direct evidence of its inadequacy for gases. This is doubtless due to the fact that most studies have been made at low pressures, and sometimes also at high temperatures, conditions which favor the applicability of the ideal gas laws to real gases.

A recent exception has been furnished by the data on the Haber equilibrium obtained by Larson and Dodge and by Larson.¹ Here it has been found that K_p , the mass action function in terms of ideal gas partial pressures, is not constant at constant temperature, as required by the theory of ideal gases, but increases definitely with the pressure. As already pointed out² we must therefore believe that K_p will vary if the concentrations are varied at constant temperature and pressure—in other words, that K_p is not strictly constant with respect to any change of condition whatever.

The contributions of previous investigators to the theory have been discussed at length in Part I of the present series³ of three papers. Here we shall repeat only the previous results of present interest.

¹ Larson and Dodge, *THIS JOURNAL*, **45**, 2918 (1923); Larson, *ibid.*, **46**, 367 (1924).

² Gillespie, *ibid.*, **47**, 305 (1925).

³ Gillespie and Beattie, *Phys. Rev.*, **36**, 743 (1930); Part II, *Phys. Rev.*, **36**, 1008 (1930). In this part the heat of reaction was calculated at various temperatures and pressures, and the entropy and energy constants of ammonia were found.